

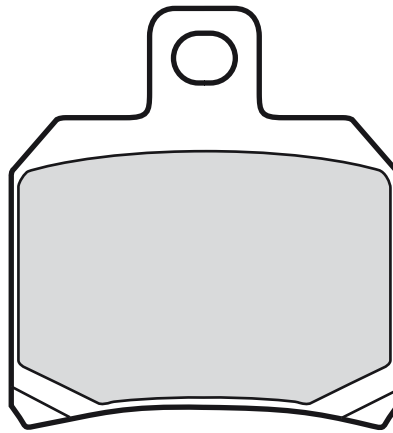

|                 |                |
|-----------------|----------------|
| <b>07004.XS</b> | 50,2x53,2x 7,8 |
| <b>07004.CC</b> | " " "          |
| <b>07004.18</b> | " " "          |
| <b>GENUINE</b>  |                |
| <b>07004.30</b> | " " "          |
| <b>GENUINE</b>  |                |
| <b>07004.35</b> | " " "          |
| <b>GENUINE</b>  |                |
| <b>07004.65</b> | " " "          |
| <b>GENUINE</b>  |                |

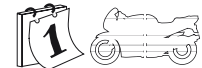

3

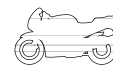
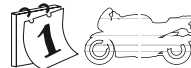
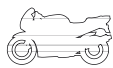
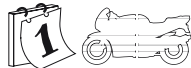

### ADIVA

|         |    |   |
|---------|----|---|
| 50 SR R | 05 | • |
|---------|----|---|

### APRILIA

|       |    |   |
|-------|----|---|
| 50 RS | 06 | • |
|-------|----|---|

### DERBI

|         |    |   |
|---------|----|---|
| 50 GP1  | 05 | • |
| 250 GP1 | 05 | • |

### GILERA

|                        |         |   |
|------------------------|---------|---|
| 500 NEXSUS (EURO 3)    | 06      | • |
| 500 NEXSUS SP (EURO 3) | 06      | • |
| 500 NEXUS              | 03 > 05 | • |
| 800 GP 800             | 07      | • |
| 800 GP800              | 09      | • |

### MBK

|                |    |   |
|----------------|----|---|
| 125 SKYCRUISER | 06 | • |
| 125 SKYLINER   | 02 | • |
| 125 THUNDER    | 01 | • |

|              |    |   |
|--------------|----|---|
| 150 SKYLINER | 01 | • |
| 150 THUNDER  | 02 | • |
| 180 SKYLINER | 04 | • |

### PEUGEOT

|                           |    |   |
|---------------------------|----|---|
| 50 SPEEDFIGHT 3 LC, LC RS | 10 | • |
| 125 CITY STAR             | 11 | • |

### PIAGGIO

|                        |         |     |
|------------------------|---------|-----|
| 125 X8                 | 04      | •   |
| 125 X9                 | 00 > 02 | • • |
| 125 X9                 | 03      | •   |
| 125 X9 (right caliper) | 04 > 05 | •   |
| 180 X9                 | 00 > 02 | • • |
| 200 X8                 | 04      | •   |
| 200 X9                 | 03      | • • |
| 250 X9                 | 00 > 02 | • • |
| 250 X9                 | 03      | •   |
| 500 BEVERLY            | 03      | •   |
| 500 BEVERLY CRUISER    | 08      | • • |
| 500 BV                 | 06      | • • |

|                       |         |     |
|-----------------------|---------|-----|
| 500 X9                | 00 > 02 | • • |
| 500 X9 EVOLUTION, ABS | 04      | •   |

### RIEJU

|                             |    |     |
|-----------------------------|----|-----|
| 50 MRT PRO, PRO SUPERMOTARD | 09 | • • |
| 50 TANGO                    | 08 | •   |

### SUZUKI

|             |         |   |
|-------------|---------|---|
| 125 BURGMAN | 01 > 06 | • |
| 150 BURGMAN | 04      | • |

### YAMAHA

|                         |    |   |
|-------------------------|----|---|
| 125 MAJESTY             | 01 | • |
| 125 MAXSTER             | 01 | • |
| 125 X-CITY              | 08 | • |
| 125 X-MAX               | 06 | • |
| 125 X-MAX               | 10 | • |
| 125 X-MAX SPORT EDITION | 11 | • |
| 150 MAJESTY             | 01 | • |
| 150 MAXSTER             | 01 | • |
| 180 MAJESTY             | 04 | • |





**07005.CC** 69,8x 41x 8,2  
85,1x42,9x 8,2

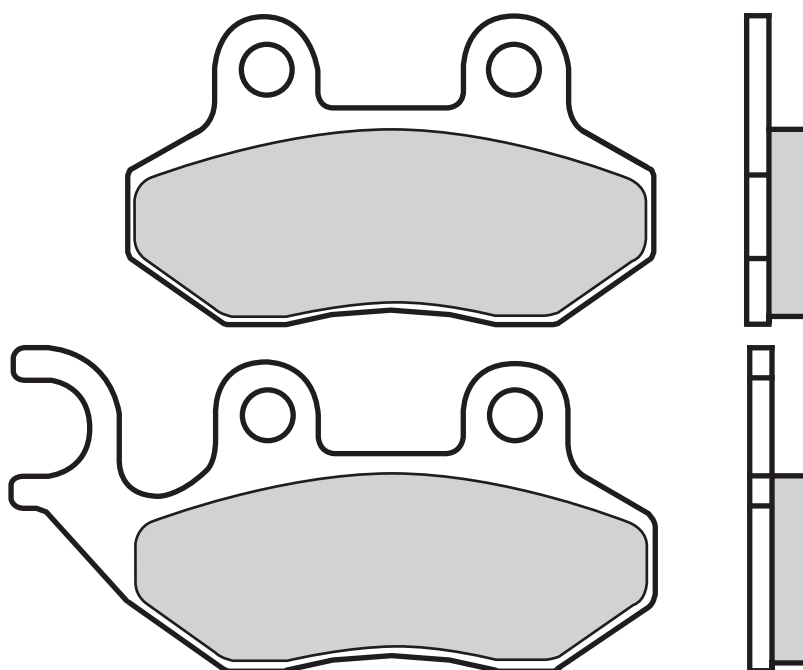

**3**



### CAGIVA

|     |            |    |   |
|-----|------------|----|---|
| 50  | CITY LUCKY | 95 | • |
| 125 | PASSING    | 95 | • |

### GARELLI

|     |           |    |   |
|-----|-----------|----|---|
| 50  | KRS       | 02 | • |
| 50  | SPORT PMX | 00 | • |
| 125 | FREELAND  | 02 | • |
| 125 | T-TEX     | 00 | • |
| 150 | FREELAND  | 02 | • |

### PGO

|     |         |    |   |
|-----|---------|----|---|
| 50  | DR.BIG  | 01 | • |
| 50  | G-MAX   | 06 | • |
| 50  | I DEP   | 09 | • |
| 50  | LIBRA   | 10 | • |
| 50  | LIGERO  | 06 | • |
| 50  | PMX     | 01 | • |
| 50  | SPORT   | 01 | • |
| 50  | T-REX   | 99 | • |
| 100 | LIGERO  | 06 | • |
| 100 | MY BUBU | 02 | • |
| 110 | T-REX   | 99 | • |
| 125 | CHARGE  | 02 | • |
| 125 | LIBRA   | 10 | • |
| 125 | LIGERO  | 06 | • |
| 125 | MY BUBU | 02 | • |
| 125 | T-REX   | 99 | • |
| 125 | X-HOT   | 10 | • |
| 150 | TR 3    | 02 | • |
| 150 | T-REX   | 01 | • |

### SANYANG

|     |             |         |   |
|-----|-------------|---------|---|
| 50  | JET         | 95 > 98 | • |
| 50  | JUNGLE      | 96      | • |
| 50  | RED DEVIL   | 97      | • |
| 50  | SUPER FANCY | 95 > 97 | • |
| 100 | PARTY       | 97      | • |
| 100 | SUPER FANCY | 95      | • |
| 125 | ATTILA      | 95      | • |
| 125 | SUPER DUKE  | 95      | • |
| 150 | SUPER DUKE  | 96      | • |

### SYM

|     |                |         |   |
|-----|----------------|---------|---|
| 50  | ALLO           | 0       | • |
| 50  | FIDDLE         | 09      | • |
| 50  | JET            | 95      | • |
| 50  | JET 4 NAKED, R | 11      | • |
| 50  | Jet Basix      | 07      | • |
| 50  | JET EURO X     | 05      | • |
| 50  | JET SPORT X    | 06      | • |
| 50  | JUNGLE         | 96      | • |
| 50  | MASK           | 00      | • |
| 50  | MASK LC        | 00      | • |
| 50  | RED DEVIL      | 97      | • |
| 50  | SUPER FANCY    | 95 > 97 | • |
| 50  | SYMPHONY       | 09      | • |
| 50  | SYMPHONY SR    | 11      | • |
| 50  | SYMPLY         | 08      | • |
| 100 | JET            | 00      | • |
| 100 | JET EURO X     | 05      | • |
| 100 | JET SPORT X    | 06      | • |
| 100 | PARTY          | 97      | • |

|     |             |    |   |
|-----|-------------|----|---|
| 100 | SUPER FANCY | 95 | • |
| 110 | STAR        | 03 | • |
| 125 | ALLO        | 0  | • |
| 125 | ATTILA      | 00 | • |
| 125 | CITYCOM     | 09 | • |
| 125 | FIDDLE      | 09 | • |
| 125 | GTS         | 07 | • |
| 125 | HD EVO DT   | 10 | • |
| 125 | JET 4       | 11 | • |
| 125 | MEGALO      | 02 | • |
| 125 | NEW DUKE    | 00 | • |
| 125 | SUPER DUKE  | 00 | • |
| 125 | SYMPHONY    | 09 | • |
| 125 | SYMPHONY SR | 11 | • |
| 125 | SYMPLY      | 08 | • |
| 150 | ATTILA      | 00 | • |
| 150 | FIDDLE II   | 11 | • |
| 150 | SUPER DUKE  | 96 | • |
| 150 | SYMPHONY    | 10 | • |
| 150 | SYMPHONY SR | 11 | • |
| 200 | FIDDLE II   | 11 | • |
| 200 | HD Evo      | 07 | • |
| 300 | CITYCOM     | 09 | • |

### TGB

|    |            |    |   |
|----|------------|----|---|
| 50 | AKROS TEC. | 94 | • |
|----|------------|----|---|

