

MONORACK SPECIFICO - SPECIFIC MONORACK
MONORACK SPECIFIQUE - SPEZIFISCHES MONORACK - MONORACK ESPECÍFICO

BMW K1200RS 1997/2002

ISTRUZIONI DI MONTAGGIO - MOUNTING INSTRUCTIONS
INSTRUCTIONS DE MONTAGE - BAUANLEITUNG - INSTRUCCIONES DE MONTAJE

**PREPARAZIONE AL MONTAGGIO
MOUNTING INSTRUCTION
PRÉPARATION AU MONTAGE
VOR DER MONTAGE
PREPARACIÓN DEL MONTAJE**

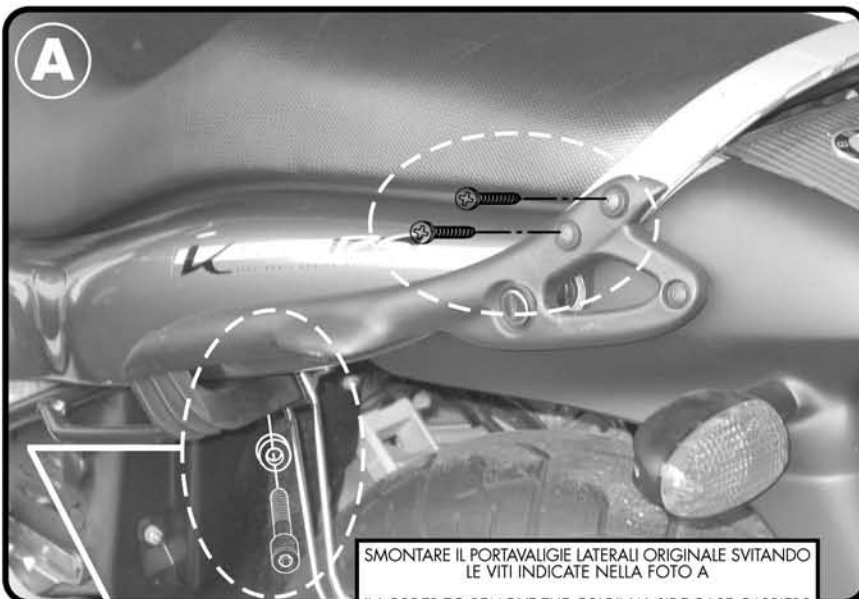

SMONTARE IL PORTAVALIGIE LATERALI ORIGINALE SVITANDO LE VITI INDICATE NELLA FOTO A

IN ORDER TO REMOVE THE ORIGINAL SIDE-CASE CARRIERS UNSCREW THE SCREWS AS SHOWN IN PICTURE A

DÉMONTÉ LES SUPPORTS DES V EN DÉVISSANT LES VIS INDICUÉES SUR LA PHOTO A

UM DIE ORIGINAL-SEITENKOFFERTRÄGER ABZUMONTIEREN, MÜSSEN DIE SCHRAUBEN WIE IM BILD A ABGEBILDET IST, ENTFERNT WERDEN

DESMONTAR LOS PORTAEQUIPAJE LATERALES ORIGINALES DESTORNILLANDO LOS TORNILLOS INDICADOS EN LA FOTO A

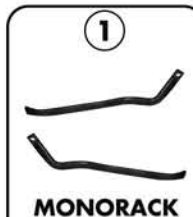

MONORACK

Q.TY n.2(Dx-Sx)



SUPPORTO
SUPPORT
SUPPORT
TRAEGER
SOPORTES

Q.TY n.2(Dx-Sx)



VITE TCEI M6x25
SCREW M6x25
VIS M6x25
SCHRAUBE M6x25
TORNILLO M6x25

Q.TY n.2



RONDELLA Ø6
WASHER Ø6
RONDELLE Ø6
SCHEIBE Ø6
ARANDELA Ø6

Q.TY n.2



DADO SPECIALE
BOLT
ECROU
MUTTER
TUERCA

Q.TY n.2



VITE TCEI M8x45
SCREW M8x45
VIS M8x45
SCHRAUBE M8x45
TORNILLO M8x45

Q.TY n.2



SMONTARE LE CARENATURE LATERALI SVITANDO LE VITI INDICATE NELLA FOTO B

IN ORDER TO REMOVE THE SIDE FAIRING UNSCREW AS SHOWN IN PICTURE B

DÉMONTÉ LES CARÉNAGES LATÉRAUX EN DÉVISSANT LES VIS INDICUÉES SUR LA PHOTO B

UM DIE SEITENTEILE VERKLEIDUNGSTEILE DES MOTORRADES ZU ENTFERNEN, LÖSEN SIE DIE ORIGINAL SCHRAUBEN WIE IM BILD B GEZEIGT WIRD

DESMONTAR EL CARENADO LATERAL DESTORNILLANDO LOS TORNILLOS INDICADOS EN LA FOTO B

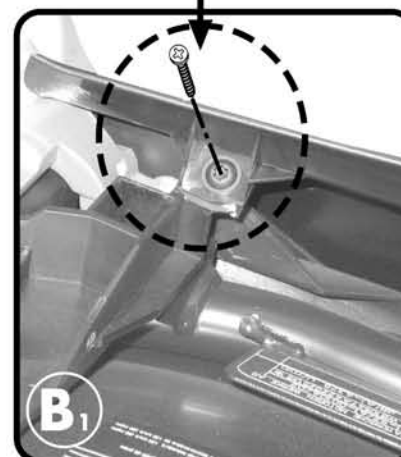

SVITARE LA VITE INDICATA NELLA FOTO C PER LIBERARE IL PARAFANGO

UNSCREW THE SCREW SHOWN IN THE PICTURE C IN ORDER TO RELEASE THE FENDER

DÉVISSER LA VIS INDICUÉE SUR LA PHOTO C POUR LIBÉRER LE GARDE-BOUE

LÖSEN SIE DIE SCHRAUBE AB WIE IM BILD C GEZEIGT WIRD, UM DEN KOTSCHÜTZER ABZUNEHMEN

DESTORNILLAR EL TORNILLO INDICADO EN LA FOTO C PARA DESENGANCHAR EL GUARDABARRO

MONORACK SPECIFICO - SPECIFIC MONORACK
MONORACK SPECIFIQUE - SPEZIFISCHES MONORACK - MONORACK ESPECÍFICO

BMW K1200RS 1997/2002

ISTRUZIONI DI MONTAGGIO - MOUNTING INSTRUCTIONS
INSTRUCTIONS DE MONTAGE - BAUANLEITUNG - INSTRUCCIONES DE MONTAJE

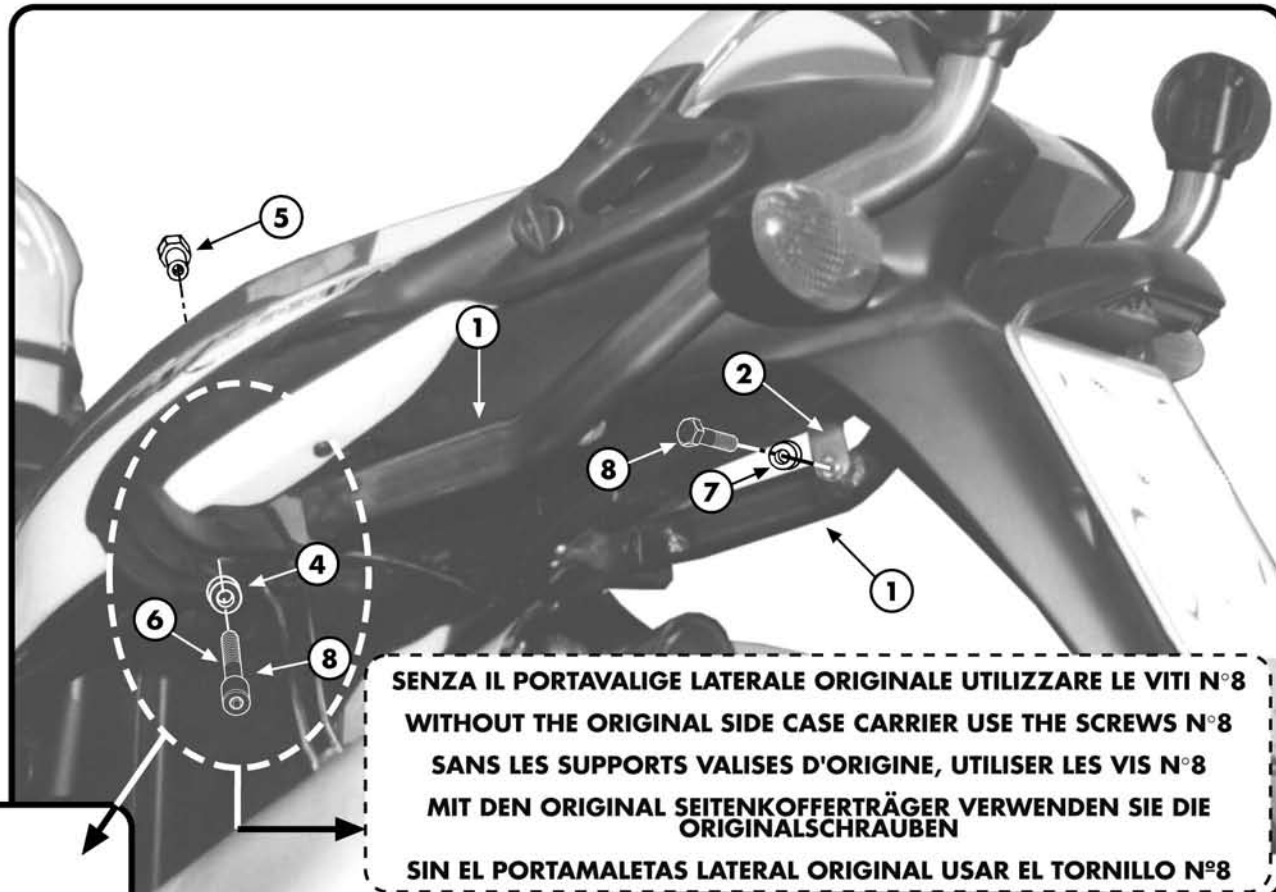
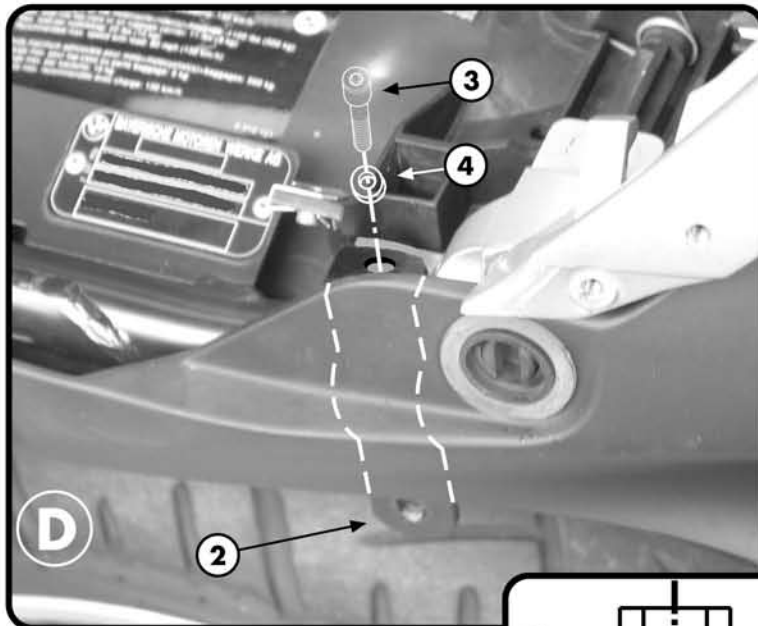

SENZA IL PORTAVALIGIE LATERALE ORIGINALE UTILIZZARE LE VITI N°8
WITHOUT THE ORIGINAL SIDE CASE CARRIER USE THE SCREWS N°8
SANS LES SUPPORTS VALISES D'ORIGINE, UTILISER LES VIS N°8
MIT DEN ORIGINAL SEITENKOFFERTRÄGER VERWENDEN SIE DIE ORIGINALSCHRAUBEN
SIN EL PORTAMALETAS LATERAL ORIGINAL USAR EL TORNILLO N°8

MONORACK

TELAIO MOTO
MOTORCYCLE CHASSIS
CARNAGE DE LA MOTO
MOTORRADRAHMEN
CHASIS MOTOCICLO

PORTAVALIGIE LATERALI
ORIGINALE

ORIGINAL SIDE-CASE CARRIER
ORIGINAL

ALISES LATÉRAUX ORIGINAUX
SEITENKOFFERTRÄGER

PORTAEQUIPAJE LATERALES
ORIGINALES

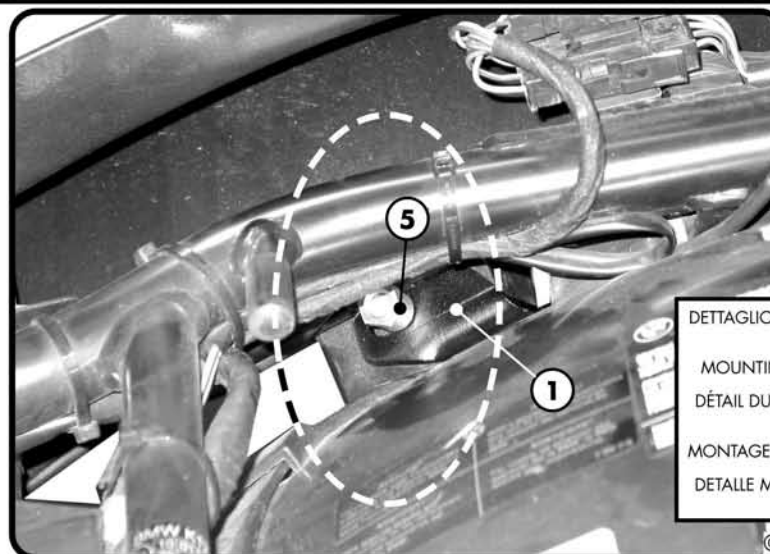
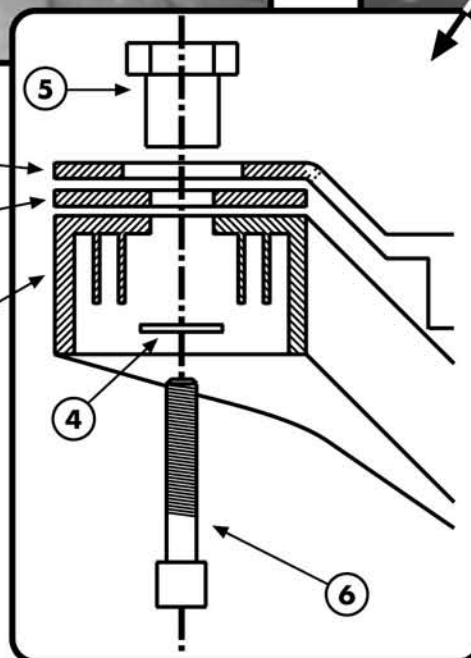

DETTAGLIO MONTAGGIO DADO SPECIALE NEL VANO
SOTTOSELLA

MOUNTING THE SPECIAL NUT UNDER THE SADDLE

DÉTAIL DU MONTAGE DE L'ECROU SPÉCIAL SOUS LA
SELLE

MONTAGE DER SPEZIELLEN MUTTER UNTER DEM SATTEL

DETALLE MONTAJE TUERCA ESPECIAL EN EL ESPACIO
DEBAJO EL SILLÍN