

ITALIA
VITE ORIGINALE
PARTE ORIGINALE
(*) BLOCCARE CON FRENAFILETTI DEBOLE
(**) BLOCCARE CON FRENAFILETTI FORTE
MONTAGGIO CAMBIO NORMALE
MONTAGGIO CAMBIO ROVESCiato
VERIFICARE SERRAGGIO VITI PRIMA DELL'UTILIZZO

ENGLAND
ORIGINAL SCREW
ORIGINAL PART
(*) LOCKING WITH LOW STRENGTH THREAD LOCKER
(**) LOCKING WITH HARD STRENGTH THREAD LOCKER
NORMAL MODE
REVERSE MODE
CONTROL THE THIGHTENING'S SCREW BEFORE USING

FRANCE
ECROU ORIGINE
PIECE ORIGINE
(*) BLOCAGE AVEC FREIN FILET FAIBLE
(**) BLOCAGE AVEC FREIN FILET FORT
MONTAGE VITESSE NORMALE
MONTAGE VITESSE INVERSEE
VERIFIER SERRAGE AVANT UTILISATION

DEUTSCHLAND
ORIGINAL SCHRAUBE
ORIGINAL TEIL
(*) BEFESTIGEN MIT MITTLEREN SCHRAUBEN SICHERUNGSMITTEL
(**) BEFESTIGEN MIT HARTEM SCHRAUBEN SICHERUNGSMITTEL
EINBAU MIT NORMALE SCHALTUNG
EINBAU MIT GEKIPPTER SCHALTBEHEL
VOR DEN GEBRAUCH SCHRAUBEN PRUFEN

ESPAÑA
TORNILLO ORIGINAL
PIEZA ORIGINAL
(*) SELLAR CON SELLADOR DEBIL
(**) SELLAR CON SELLADOR FUERTE
MONTAJE CAMBIO NORMAL
MONTAJE CAMBIO INVERSO
VERIFICAR EL APRIETE ANTES DE UTILIZARLO

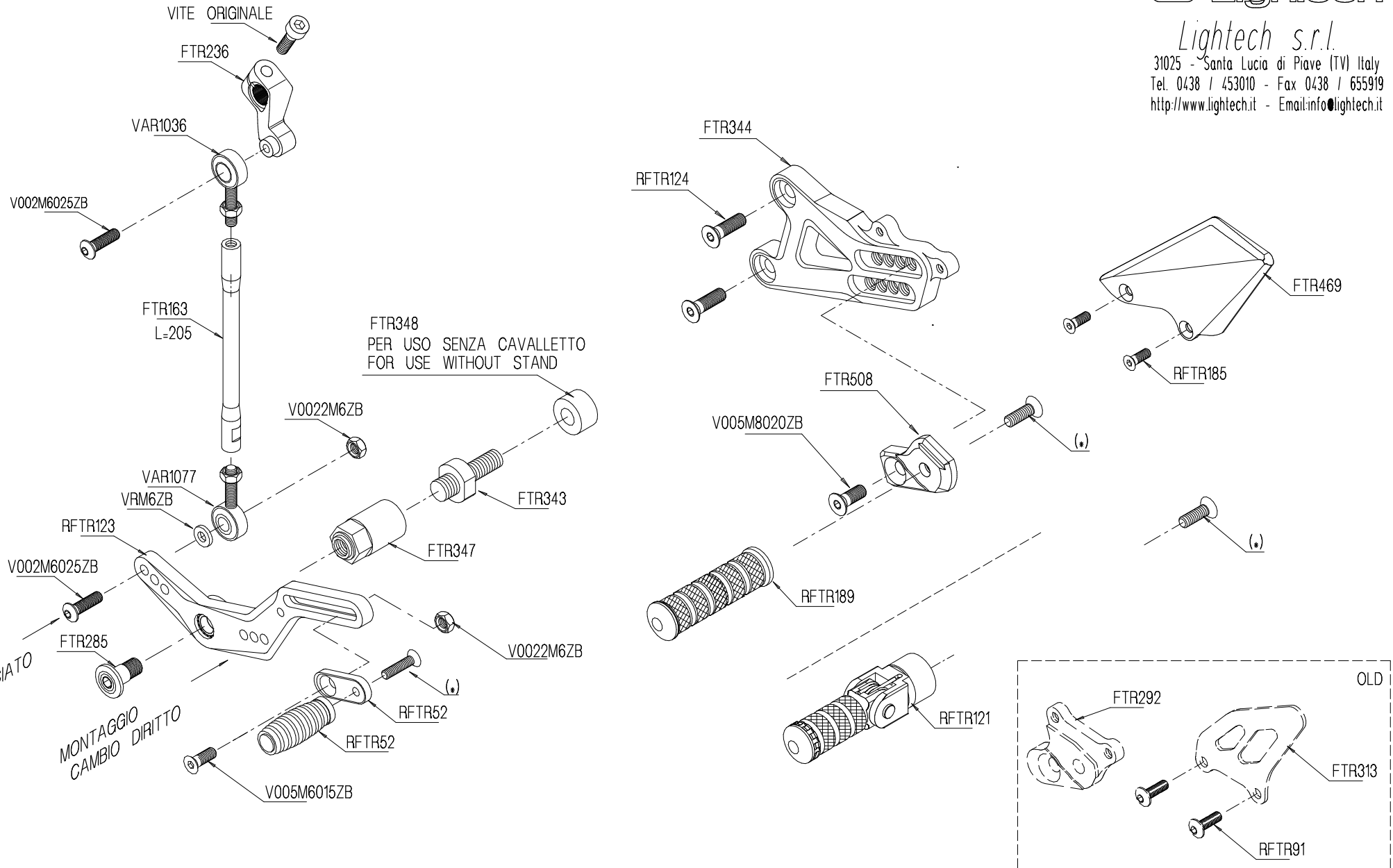

ITALIA
VITE ORIGINALE
PARTE ORIGINALE
(.) BLOCCARE CON FRENAFILETTI DEBOLE
(..) BLOCCARE CON FRENAFILETTI FORTE
MONTAGGIO CAMBIO NORMALE
MONTAGGIO CAMBIO ROVESCIAIO
VERIFICARE SERRAGGIO VITI PRIMA DELL'UTILIZZO

ENGLAND
ORIGINAL SCREW
ORIGINAL PART
(.) LOCKING WITH LOW STRENGHT THREAD LOCKER
(..) LOCKING WITH HARD STRENGHT THREAD LOCKER
NORMAL MODE
REVERSE MODE
CONTROL THE THIGHTENING'S SCREW BEFORE USING

FRANCE
ECROU ORIGINE
PIECE ORIGINALE
(.) BLOCCAGE AVEC FREIN FILET FAIBLE
(..) BLOCCAGE AVEC FREIN FILET FORT
MONTAGE VITESSE NORMALE
MONTAGE VITESSE INVERSEE
VERIFIER SERRAGE AVANT UTILISATION

DEUTSCHLAND
ORIGINAL SCHRAUBE
ORIGINAL TEIL
(.) BEFESTIGEN MIT MITTLEREN SCHRAUBEN SICHERUNGSMITTEL
(..) BEFESTIGEN MIT HARTEM SCHRAUBEN SICHERUNGSMITTEL
EINBAU MIT NORMALE SCHALTUNG
EINBAU MIT GEKIPTE SCHALTHEBEL
VOR DEN GEBRAUCH SCHRAUBEN PRUFEN

ESPAÑA
TORNILLO ORIGINAL
PIEZA ORIGINAL
(.) SELLAR CON SELLADOR DEBIL
(..) SELLAR CON SELLADOR FUERTE
MONTAJE CAMBIO NORMAL
MONTAJE CAMBIO INVERSO
VERIFICAR EL APRIETE ANTES DE UTILIZARLO