

Before installing this product, check the contents of the kit. If anything is missing, please contact your nearest Öhlins dealer.

Kit Contents

	Part No.	Pcs.
Shock absorber	SU 888	1
Öhlins Sticker	00192-01	2
Memo Notes Sticker	01180-01	1
Owner's Manual	07242-01	1

Please note that during storage and transportation, especially at high ambient temperature, some of the oil and grease used for assembling may leak and stain the packaging. This is in no way detrimental to the product, wipe off the excessive oil/grease with a cloth.

⚠ Warning!

Before installing this product, read the Öhlins Owner's Manual. The shock absorber is an important part of your vehicle and will affect the stability.

Öhlins products are subject to continuous improvement and development, therefore, although these instructions include the most up-to-date information available at the time of printing, minor updates may occur.

To find the latest information contact your Öhlins distributor. Please consult your Öhlins dealer if you have any questions regarding the contents in this document.

Part no. SU888_0
Issued 2009-03-17



© Öhlins Racing AB. All rights reserved. Any reprinting or unauthorized use without the written permission of Öhlins Racing AB is prohibited.

Öhlins Racing AB
Box 722
S-194 27 Upplands Väsby, Sweden
Phone +46 8 590 025 00
fax +46 8 590 025 80



www.ohlins.com

Shock Absorber for Suzuki GSXR1000 **SU 888**

Mounting Instructions



⚠ Warning!

It is advisable to have an Öhlins dealer install the shock absorber.

When installing, consult your Vehicle Service Manual.

1

Put the motorcycle on a workstand so that the rear wheel barely touches the ground.

⚠ Warning!

Make sure the vehicle is securely supported so that it will not tip.

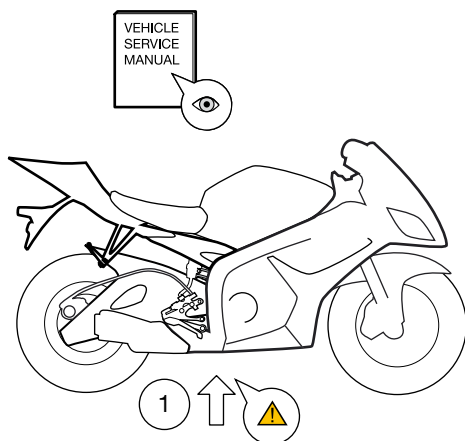

2

Remove the upper and lower attachments of the original shock absorber.

3

Remove the original shock absorber by lifting it above the rear wheel.

⚠ Caution!

The brake hose must not be stretched. It can be damaged. Support the swing arm once the lower screw of the shock absorber is removed.

👁 Note!

Before installing the Öhlins shock absorber clean the vehicle thoroughly.

4

Install the Öhlins shock absorber in the same way as the original unit. Use the original attachment screws.

👁 Note!

Lower the motorcycle so that the shock absorber is slightly compressed, before tightening the screws.

👁 Note!

Make sure that there is clearance between the shock absorber reservoir and the brake fluid reservoir.

5

Make sure that all removed parts are reinstalled in the same way as they were before the installation of the Öhlins shock absorber.

⚠ Caution!

Make sure that all screws are tightened to the correct torque and that nothing fouls or restricts movement of the shock absorber when the suspension is fully compressed or extended.

⚠ Warning!

Before riding, always make sure that the basic settings made by Öhlins are according to recommended Set-up Data. Read about adjustments and setting up in the Öhlins Owner's Manual before you make any adjustments. Contact an Öhlins dealer if you have any questions about setting up the shock absorber.

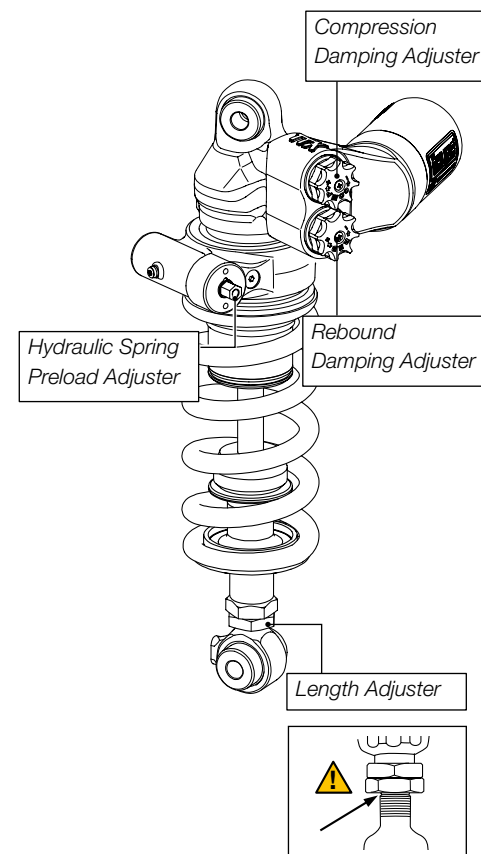

Set-up Data

Recommended set-up

Spring preload	14 mm	Shock absorber length	320 ⁺⁴ / ₋₂ mm
Compression	12 clicks	Stroke	63 mm
Rebound damping	12 clicks	Spring	21040-31 (95 N/mm)
		Free spring length	160 ⁰ / ₋₃ mm
		Free Sag (R1-R2)	15 mm
		Ride Height (R1-R3)	28 mm
		👁 Read about Free Sag and Ride height in the Öhlins Owner's Manual.	